

Structural Analysis and Design Optimization for Handle Bar Assembly of Motor-cycle



Mr.Chandrakant S. Khemkar¹ and Prof. Ganesh A. Kadam²

¹ckhemkar@gmail.com
²ganeshkadam07@gmail.com

^{#1}Student of M.E. (Design Engineering), STES's SKN Lonavala, Savitribai Phule Pune University, India

^{#2}Faculty member of Mechanical Engineering, STES's SKN Lonavala, Savitribai Phule Pune University, India

ABSTRACT

In the 21st century, technology is omnipresent in day to day life of growing industrial sector. Motorcycle handlebar refers to the steering mechanism for motorcycles. Handlebars often support part of the rider's weight, and provide a mounting place for controls such as brake, throttle, clutch, horn, light switch, and rear view mirrors. The two-wheeler and the four-wheeler industry are normally faced with challenges related to function and safety. The scope of this dissertation work falls in this area where the design and optimization of the Handlebar assembly needs to be reviewed for the sake of failure during use. For our case, the housing of the handle bar and assembly is met with failure near the accelerator end of the handle. A study is being initiated by identifying the source of this failure of the handle bar assembly addressing the same with modified or improved design features for reducing the incidence of failure. Whole handle bar assembly is more susceptible to the failures as it experience numerous forces such as bumps, braking, engine vibrations, rider force, road excitations etc. Finite Element Analysis would be deployed for the structural analysis using Radios or suitable solver. For this work, experimentation shall be performed for validating the performance parameter identified as 'Buckling' of Handlebar. The load Vs displacement shall be recorded using load cells with data logger to display results. Variants shall be proposed for study and analysis.

Keywords: Handle Bar, Structural Analysis, FEA, Optimization.

ARTICLE INFO

Article History

Received :18th November 2015

Received in revised form :

19th November 2015

Accepted : 21st November , 2015

Published online :

22nd November 2015

I.INTRODUCTION

In recent periods requirements from customer are increasing according to safety, cost, reliability, comfort of product in automotive sector. As our project Structural analysis and design Optimization of two wheeler handle bar assembly having some challenges and infields customer complaints to enhance functionality, reliability, customer comfort and safety the optimum Design of component to be find out and validate from higher authority [1]. The two-wheeler and the four-wheeler industry are normally faced with challenges related to function and safety. The compliance of vehicle in this regard is of utmost importance while the same could be approved by the concerned regulatory authorities for being used on the

public roads [1]. Besides, all other parts and components that support and/or form an integral part of the assembly of the sub-system could be required to comply with the norms.The Handle Bar is designed to accommodate the effects of a wide range of loading conditions resulting from internal and external pressure and bending, including the deformations during installation and operations [2]. The other areas attracting compliance are the warranty claims received from the customer during usage over the field or the report filed by the concerned field Engineer observing the field test for the vehicle. The breakage and/or damage to the component could be highlighted during the time the vehicle is put to actual use. The scope of this dissertation work falls in this area where the

design of the component or the sub-assembly needs to be reviewed for the sake of failure during use.

II. LITERATURE REVIEW

J.E. Akin [1] presented the concepts of stress analysis will be stated in a finite element context in International Journal of Industrial Ergonomics. That means that the primary unknown will be the (generalized) displacements. All other items of interest will mainly depend on the gradient of the displacements and therefore will be less accurate than the displacements.

Harale Shivraj and Gyanendra Roy [2] presented paper shows that the weight constraint to enhance the performance is playing main role in design and development life cycle. The biggest challenge in design phase is to predict the potential failures as early as possible. Handlebar assembly is more susceptible to the failure because of various types of loading such as bump, braking, road excitations etc. Modal Frequency Response analysis enables to analyze the strength of structural mountings within the excitation frequency range on the vehicle.

Arash Behrouzi [3] presented in this paper an analytical approach for one step modification of the tooling shape in channel forming process to compensate the spring back error. The results of the analytical approach coincide with those of FE approach. The accuracy of the obtained results is verified by the experimental results. Here methodology is considered and process by which analytical and experimental result are taken and compared are studied.

David Lopez, [4] presented a paper shows that separating the bicycle into smaller segments of beams with stresses and moments to be the most effective way in constructing and designing the bicycle. All of the calculations were aimed to observe all the stresses that could potentially affect the bicycle design when a load Applied by rider of 250 lbs and acceleration of 15 m/s². Although the bicycle could clearly be separated into smaller members much more, the five designs in this project cover enough information of the needed parts when looking at and construction of bicycle. Also, in this project friction was not factored considered upon designing this project, we found the importance of yield, maximum, principle, and shear stresses. These maximum stress values are necessary especially when provided with a factor safety in confirming a small possibility of failure. This paper is helpful for importance of selection of material and sectioning of parts of component for analysis point of view.

III. PROBLEM STATEMENT & SCOPE of ASSIGNMENT

Automobile bike steering assembly contains different components like handle bar, housing, frame etc. In that mostly handle bar fail in the course of use. These recalls are expensive for manufactures and lead to cause of accident to rider, to avoid failure of the component which could be reason to serious injury [2]. This study was started to support in improvement of design and product qualification of handle bar assembly. With the help of input parameter CAD model of

handle bar for different loading condition failure can be predicted before the component is produced through the analysis by use of software which based on FEA principles [3], [4]. The prediction at the component design stage ensures that the chosen geometry is compatible with the conditions of use [1]. Experiments are to be conducted on the test rig at the client premises. The assembly would be mounted on the rig and the frequency of the cyclic loading for torque and or buckling would be set based on the historical data as well as the input received from the analysis data. The FEA analysis would typically include the following components/subassembly, though the prime focus would remain over the key component/s of the handle bar:

1. Handle bar Pipe (Material – CRCA/ Stainless Steel Rolled Pipe).
2. Casing/ Housing for the Pipe or base for the pipe (Aluminum Die Casting/ M.S. block machined to size).
3. Base for the Housing (M.S. Plate/ Sheet screwed or welded over the Frame).
4. Frame for the Motor-cycle (or Two-wheeler).

After stress analysis scope for optimizations is to be studied. Weight of component reduced without compromising in strength or safety. Stress is criteria for weight optimization. As it mass production component it will save much more cost.

IV. METHDOLOGY

The main Objective of this paper is to analyze the handle bar assembly of motor-cycle for performance enhancement to increase safety and comfort and reduce accidents. That finds out the point on handle bar cross section that experiences the maximum stress [4]. When handle bar exposed to load applied by rider hands, that varies accidentally in both magnitude and direction As mentioned in scope of assignment depending upon the problem methodology is as follows.

- Input data for Problem / Test conditions.
- Material selection based on material properties strength and its loading condition with magnitude of load.
- Use of CAE for identifying solutions.
- Find out results using CAE for different loading condition.
- Optimize the design by weight reduction and cost saving.
- By using experimentation with test setup take different readings for different loading condition.
- Compare the analytical and experimental results.
- Verification and Validation of design based on results.
- Documenting results for further improvement/ research.

V. FINITE ELEMENT ANALYSIS

Drawings of handle bar

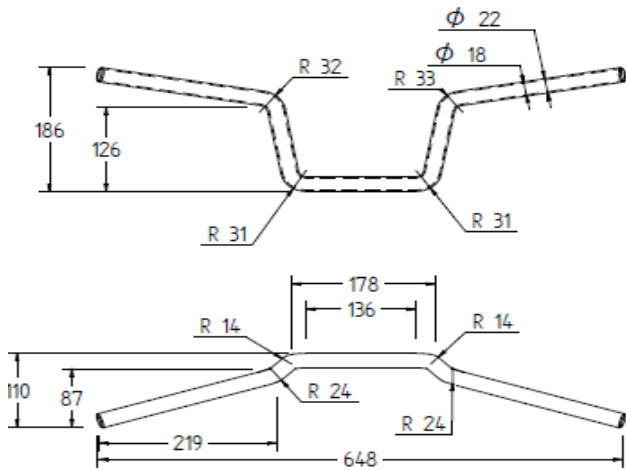

Fig. 1 Front and Top view of handle bar

A. Material & properties

TABLE 1

COMPONENTS AND MATERIALS OF HANDLE BAR ASSEMBLY

Sr. No.	Component	Material	Modules N/mm ²	Poisson's ratio	Density Ton/mm ³
1	Handle Bar	Steel/CRCA (C35)	2.1*10 ⁵	0.3	2.7*10 ⁻⁹
2	Base for Pipe	Al Si 132	7.6*10 ⁵	0.3	7.9*10 ⁻⁹
3	Frame	Steel (C35)	2.1*10 ⁵	0.3	2.7*10 ⁻⁹

B. Preparation for analysis

Loading condition: Following figure shows the load applied by rider's hand over handle bar of a bike.



Fig. 2 Load acting over handle bar[Source – bikeadvice.net]

While braking, the rider in motion is try's to change the speed of the combined mass m of rider plus bike. This creates a negative acceleration "a" in the line of travel, the acceleration "a" causes an inertial forward force F on mass m ($F=ma$). Considering Motorist of wt. 120 kg traveling at speed of 90 km/h, suddenly apply the break and come to rest in 5 sec.

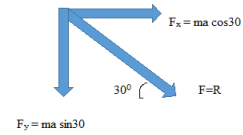

Fig. 3 Force Directions

$F^2 = F_x^2 + F_y^2$ Where, m = Mass of rider (kg),

a = Acceleration (m/s^2), F = 400 N Inclined, 700 N Vertical.

C. FEA model development

The handlebar assembly components such as handlebar, Base of Pipe and Frame are made of different material as shown in table 1. FE model has been developed by with pre-processing software Hyper Mesh. Handle bar modeled with shell elements CQUAD, Housing modeled with CTETRA by extracting mid surfaces. The connections between housing, handle bar, frame modeled with RBE2 elements as shown in meshing figure.

VI. ANALYSIS USING SOLVER RADIOSS

In this analysis stress pattern and displacement of handle of handle bar assembly for different loading condition has been observed.

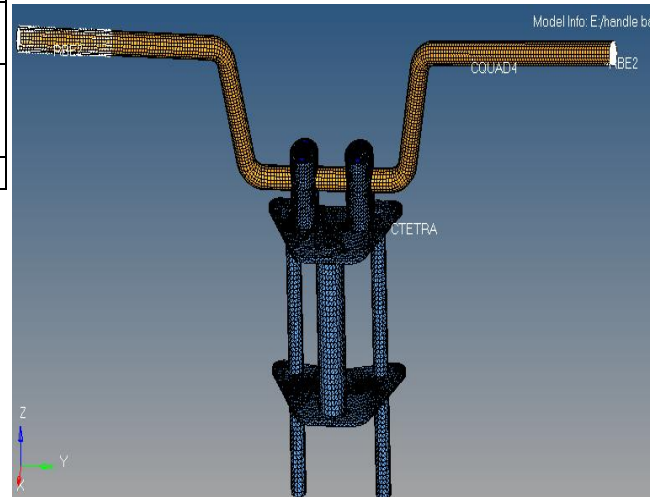

Fig. 4 Meshing of Handle Bar Assembly

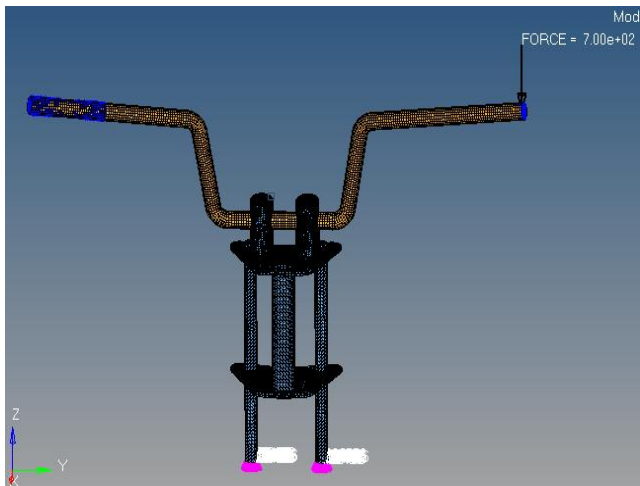

Fig. 5 force of 700N is applied vertically downward at one side of handle bar

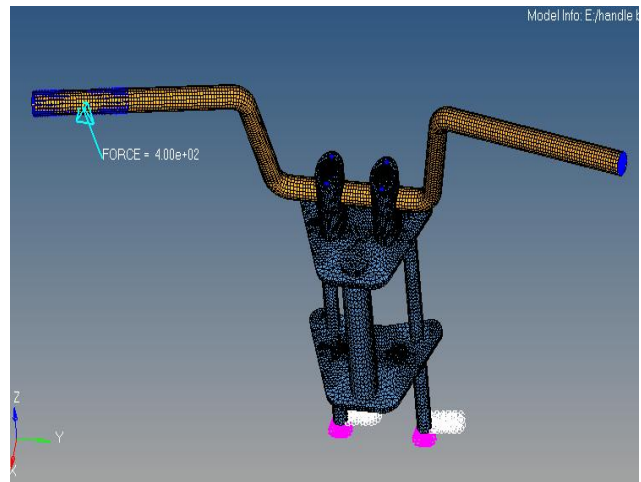

Fig. 8 Force of 400N is applied from free end at 30° Angle.

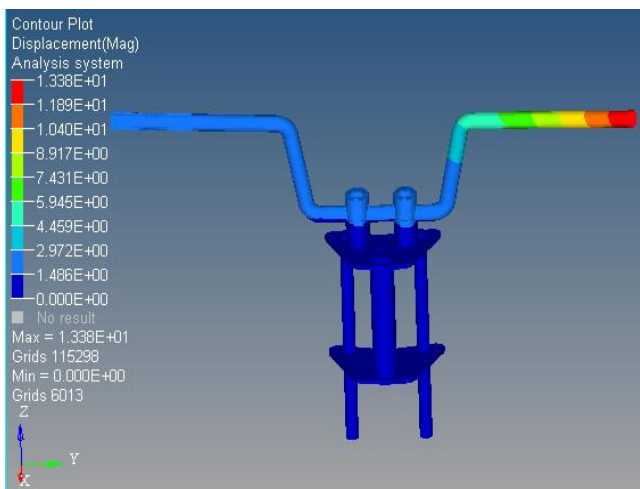

Fig. 6 Displacement pattern of handle bar assembly (Maximum Displacement 13.37mm)

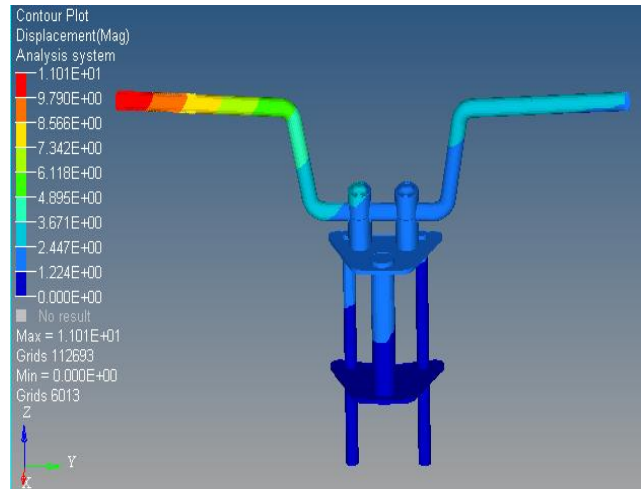

Fig. 9 Displacement pattern of handle bar assembly (Maximum Displacement 11.01mm)

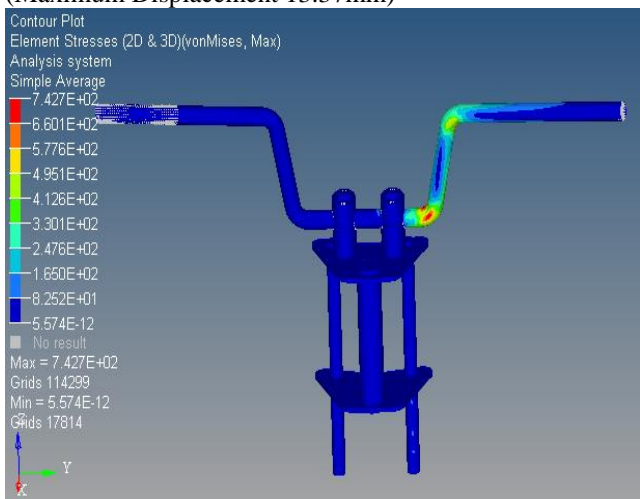
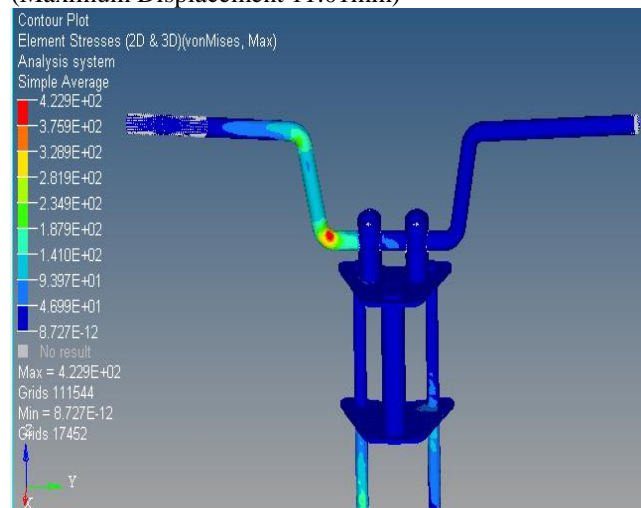

Fig. 7 Stress pattern of handle bar assembly (Maximum Stress 742.65N/mm²)



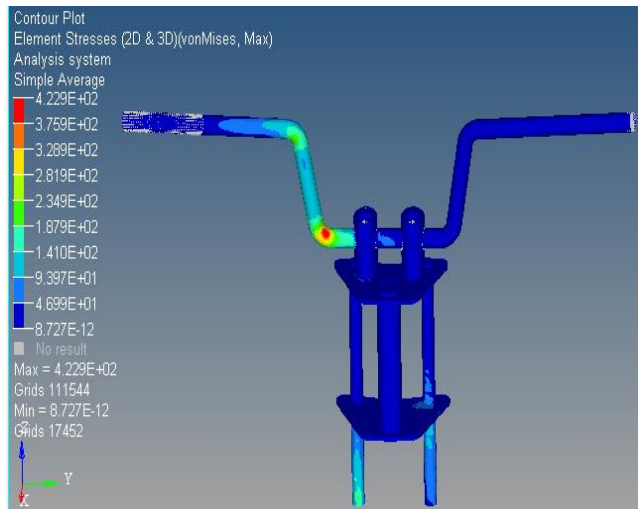

Fig. 10 Stress pattern of handle bar assembly (Maximum Stress 422.9N/mm²)

VII. MATHEMATICAL FORMULATION

Considering handle bar as cantilever beam. Force of 400N making an angle of 30° acting at free end of handle bar. Bending stress calculation: Bending stress induced in handle bar is finding out by using following equation.

$$\frac{M}{I} = \frac{\sigma}{y} = \frac{G\theta}{l}$$

Where, M = bending moment (N-M), I = Moment of inertia (m⁴), σ = Bending stress (N/mm²), G = Modulus of rigidity (N/mm²), θ = Angular twist (rad/sec), l = Length of beam (M) [15], [16].

D₀= 22mm, D_i= 18mm, t= 2mm, L=235.7 (from given geometry), Material C35, E= 2.1*10⁵ N/mm², μ= 0.3, ρ= 7.9*10⁻⁹ ton/mm³. Bending stress in above condition is given by.

$$\sigma = \frac{My}{I} \text{ N/mm}^2 \quad \text{here } y = D_0/2$$

$$I = \frac{\pi}{64} (D_0^4 - D_i^4) = \frac{\pi}{64} (22^4 - 18^4), I = 6342.80 \text{ mm}^4$$

$$M = F \cdot L = 400 \cdot 235.7, M = 94280 \text{ N-mm},$$

$$y = D_0/2 = 11 \text{ mm},$$

We get

$$\sigma = \frac{94280 \cdot 11}{6342.80}$$

$$= 163.5050 \text{ N/mm}^2$$

Deflection of beam: Deflection of beam given by formula

$$\delta = \frac{WL^3}{3EI} = \frac{400 \cdot 235.7^3}{3 \cdot 2.1 \cdot 10^5 \cdot 6342.800}$$

$$= 1.3107 \text{ mm}$$

VIII. EXPERIMENTATION

Experimentation is to be conducted on the test rig at the client premises. The assembly would be mounted on the rig and the frequency of the cyclic loading for torque, bending and or buckling would be set based on the historical data as well as the input received from the analysis data [6]. Failure can be predicted before the component is produced through the use of software which relies on FEA principles. The prediction at the component design stage ensures that the chosen geometry is compatible with the conditions of use. Close collaboration between Component designers, Process Engineers and the Test Engineers assures the compliance with very short development times.

The parameters influencing the performance of the subject application are listed below:

- Type of material.
- Mechanical properties of the material.
- Thickness of the component at a given section.
- Method of assembly and type of joint with mating parts.
- Type and magnitude of force exerted.
- Frequency of loading.

After experimentation the results are compared with results of FEA and it shows us the performance of product. For optimum design by varying the important parameter for different loading condition get different results gives us most suitable solution.

IX. CONCLUSION

As discussed in paper the method of FEA and Experimentation is very useful for development of new products. With the help of FEA we are able to design a product with high reliability and quality which is useful to increase the performance for its optimum cost. It also reduces the chances of failure and cycle time required for the development of new product. After FEA analysis experimentation is done on prototype of product to confirm the results and compare the results of FEA and experimentation to know the actual performance of the product.

ACKNOWLEDGMENT

Thanks to Prof. G. A. Kadam for his valuable guidance and contribution in preparation of this paper. I also express my deepest gratitude to management of “Advent Tool tech limited” Pune and my advisers for encourage me to right this paper.

REFERANCES

- [1] J. E. Akin, FEA Concepts: SW Simulation International Journal of Industrial Ergonomics, Draft 13.0. Copyright 2009, PP.21-29.
- [2] Harale Shivraj. N, Gyanendra Roy “Vibration Analysis of 2 Wheeler Handle-Bar Assembly” Mahindra 2 Wheelers Ltd. Mahindra 2 Wheelers Ltd. 2012, PP. 1-7.
- [3] Arash Behrouzi, Bijan Molaee Dariani, Mahmood Shakeri, Die Shape Design in Channel Forming Process by Compensation of Spring back Journal of Mechanical Engineering, vol.3/No.2/winter 2010 PP.17-26.
- [4] David Lopez, Jovan Mayfield, & Pierre Marc, “Stress Analysis of a Bicycle” Polytechnic Institute of New York University. 2010, PP. 1-12.
- [5] F. Guarracino, A.C. Walker b, A. Giordano, Effects of boundary conditions on testing of pipes and finite element modeling, International Journal of Pressure Vessels and Piping 86 (2009) PP 196–206.
- [6] Patrick L. Lizotte, A report on “Stress Analysis and Fabrication of Composite Bicycle Frames” McGill University, Montréal. 1996, PP. 1-115
- [7] Javad Marzbanrad n, Mohammad Reza Ebrahimi, Multi-Objective Optimization of aluminum hollow tubes for vehicle crash energy absorption using a genetic algorithm and neural networks, Thin-Walled Structures 49 (2011) PP 1605–1615.
- [8] Ko Ying Hao, Zaidi Mohd Ripin, Nodal control of grass trimmer handle vibration, International Journal of Industrial Ergonomics 43 (2013) PP18-30.
- [9] Cal Stone and Maury L. Hul, “Rider & bicycle Interaction Load during Standing Treadmill Cycling” Journal of applied biomechanics, by human kinetics publishers, Inc. Vol. – 9, 1993, PP. 202-218.
- [10] Jorge Juan Gil a,b, Iñaki Díaz a, Pablo Ciáurriz a, Mikel Echeverría, New driving control system with haptic feedback: Design and preliminary validation tests, Transportation Research of Part C 33 (2013) PP22–36.
- [11] S.P. McKenna, M.R. Hill, M.L. Hull, “A single loading direction for fatigue life prediction and testing of handlebars for off-road bicycles” International Journal of Fatigue, Elsevier. Vol. – 24, (2002), PP. 1149–1157.
- [12] Patil Pruthviraj Devidas, Prof. P. N. Ulhe, “Stress analysis for Handle-Bar Housing at the Accelerator of two Wheeler” Paripex - Indian journal of research. Vol.-2, Issue-7, July 2013, PP. 67-70
- [13] Jia-Hua Lin, Raymond W. McGorry, Chien-Chi Chang, Effects of handle orientation and between-handle distance on bi-manual isometric push strength Liberty Mutual Research Institute for Safety, 71 Frankland Road, Hopkinton, MA 01748, USA, Applied Ergonomics 43 (2012) PP 664-67
- [14] V. D. Kodgire, “Material Science and Metallurgy for Engineers”, Everest Publication, 2009.
- [15] V. B. Bhandari, “Design of Machine Elements” Third Edition, Tata McGraw-Hill Education, 2008.
- [16] S. Ramamurtham, “Strength of Materials”14th Edition, DhanpatRai Publishing Company (P) Limited, 2012.