

Failure railway track security system

Rohini Chavan, Snehal Solankar, Dhanashri Pawar (dhanu4912@gmail.com)

Dr. D.Y.Patil SOE,Lohegaon

ABSTRACT

In all transport systems, particularly in the case of railways, safety and reliability are highly considered. In recent years, with the development of high speed railway, speed and capability of the trains constantly improved, and traffic density gets more and more serious. As a result the requirements to the reliability and safety of the high speed train operation enhances increasingly[1].

However, safety of high speed railway extremely relies on its surrounding environment. The number of collision connected railway accidents shows world-wide an increasing tendency year by year[2].

In the technical literature very few number of publications can be found that are dealing with investigations into the train collision processes to predict the level of forces and deformations realizing in the course of accidental collisions/crashes. The shortage of the literature sources can be explained by the extremely complicated character of the dynamics of train crashes. The paper takes an attempt to develop an iterative computation method for predicting the dynamics of train collisions/crashes. The train safety has been an issue with the increasing number of incidents being reported that has caused death and injury. Majority of deaths on the railway involve third with the incursion onto the level crossings[3].

Average train accident would cost millions of Indian rupees and these can be avoided if there is a mechanism to track the train location and speed and warn the locomotive drivers about possible safety issues

The solution is a comprehensive GPS/GSM based train tracking system, which provides accurate, dependable and timely information to the controller. The inbuilt GPS module identifies the train location with a highest accuracy and transfers the information to the central system via GSM. The availability of this information allows the Train Controller to take accurate decisions as for the train location. Location data can be further processed to provide visual positioning using maps granting a wholesome view on train location.

Positioning data along with train speed helps the administration to identify the possible safety issues and react to them effectively using the communication methods provided by the system. Additionally, this project proposes a system which monitors the track in front of a train for obstacle detection using multi sensor set up. If an obstacle is detected, the inbuilt GPS module identifies the train location with a highest accuracy and transfers the information to the central system via GSM[4].

The availability of this information allows the Train Controller to take accurate decisions as for the train location. Thus we have selected a project which is simple to use and it is very cheap to make this project[5].

The other technology which is used by railway officers is quite handy ,but very complicate and it is costly. This will help railways to be in secure position and it always be needful in security purpose of our Indian Railway system.

I. LITERATURE SURVEY

We first organized a survey of existing technologies of automatic visual inspection of railroad track and track components. This gave understanding with respect to which assignments were best suited to vision based assessment for which technology was not already under development. This survey encompassed well-established inspection technologies and experimental technologies currently under development. In this section, we provide a brief review of the technologies currently in use or development that are of greatest relevance in the determination of the scope of our

research. Safety in railways is one of the major issues for public transportation organization and a fast and efficient inspection system is vital to ensure the safety of railways.

Authors had tried to provide effective solution on the problem. Let us discuss problem and solution. Previous, rail inspection methods include destructive techniques, such as coring, and non-destructive techniques, such as hammer sounding. But these methods just “cover limited space and have limited effectiveness in identifying the faults. Further non-destructive evaluation techniques for rail track inspection had developed. These technologies include visual

inspection, ground penetrating radar (GPR), infrared, X-ray and laser light.

M.Pradeep & K. Naganarasaiah Goud(2013)[1] This paper represents” Damage Detection of Railway Track by Sensor”,Ultrasonic distance measuring sensors are

widely used in many industrial establishments and particularly in the metrology area.

These sensors are used in many engineering disciplines because of their high precision

Characteristics of different methods. In addition Global positioning System (GPS) receivers and total stations are widely used in geodesy. Using the GPS receivers is very popular, particularly for navigational purposes different techniques. In this paper, a new railway track geometry surveying system, which is designed by integrating the ultrasonic sensor, Fire sensor, GPS receiver and total station, is introduced. This new surveying system is an alternative to classical geodetic measurement methods that are often used for ARM controlling the railway track geometry, To identification the location of damage detection of Track gauge, and track axis coordinates, which are railway geometrical parameters, can be instantly determined while making measurements by using the New surveying system.

S Ramesh & S Arvind (2014)[2] This paper represents, “ Automatic Track Inspection in Railway Network”

In India rail transport occupies a prominent position in providing the necessary transport infrastructure to sustain needs of a rapidly growing economy. Today, India possesses the fourth largest railway network in the world. However, in terms of the reliability and safety parameters, we have not yet reached truly global standards. The main problem about a railway analysis is detection of cracks in the structure. If these deficiencies are not controlled at early stages they might lead to a number of derailments resulting in a heavy loss of life and property. This project proposes a cost effective solution to the problem of railway track crack detection utilizing RF control assembly which tracks the exact location of faulty track which then mended immediately so that many lives will be saved.

Kalpna Sharma & Jagdish Kumawat(2014)[3] This paper represents,”

Railway Security System based on Wireless Sensor”

Railways are large infrastructures and are the prime mode of transportation in many countries. The railways have become a prime means of transportation owing to their capacity, speed, and reliability. Even a small improvement in performance of railways has significant economic benefits to rail industry. Thus, a proper maintenance strategy is required to govern optimization of inspection frequency and/or improvement in skill and efficiency. Accidents happening due to track breaking have been a big problem for railways for life security and timely management of services. This breakage needs to be identified in real time before a train actually comes near to the broken track and get subjected to an accident. In this paper, different kinds of rail defects inspection and maintenance methods are described and a basic algorithm is readdressed that makes use of wireless acoustic sensors for detecting cracks and breakages in the railway tracks.

K.Bhargavi 1, M.Janardhana Raju(2014)[4] This paper represents,”

Railway Track Crack Detection Using sensor Assembly”

In India rail transport occupies a prominent position in providing the necessary transport infrastructure to sustain needs of a rapidly growing economy. Today, India possesses the fourth largest railway network in the world. However, in terms of the reliability and safety parameters, we have not yet reached truly global standards. The main problem about a railway analysis is detection of cracks in the structure. If these deficiencies are not controlled at early stages they might lead to a number of derailments resulting in a heavy loss of life and property. This paper proposes a cost effective solution to the problem of railway track crack detection utilizing sensor assembly which tracks the exact location of faulty track which then mended immediately so that many lives will be saved.

Moorthy& Muruganathan(2015)[5] this paper represents,” Automatic identification of obstacles and crack sensing scheme in rail tracking system” A system for preventing trains from derailing and colliding with hazards on railways is disclose. According to the innovation, the system includes a safety vehicle (i.e., “trolley”) that travels along a railway a head of a train. Railway safety is a crucial aspect of rail operation the world over. Malfunctions follow-on in accidents usually get wide media coverage even when the railway is not at fault and give to rail transport, among the unaware public, an unjustified image of inefficiency often fueling calls for immediate reforms. This paper is designed at helping the railway administrations concerned to strengthen their safety culture and develop the monitoring tools required by modern safety management.

Dr.Sri Rajitha & L.Chandra Shekar(2015)[6] This paper represents, “ An Embedded Based Railway Track fault Detection Using ARM7LPC2148” The Transportation of train always depends on railway tracks (rails) only. If there is a crack in these rails, it creates a major problem. Most of the accidents in the train are caused due to cracks in the railway tracks, which cannot be easily identified. Also it takes more time to rectify this problem. In order to avoid this problem, we are using the crack detector robot, which detects the crack in the rails and gives an alarm. A robot is an apparently human automation, intelligent and obedient but impersonal machine. It is relatively, that robots have started to employ a degree of Artificial Intelligence (AI) in their work and many robots required human operators, or precise guidance throughout their missions. Slowly, robots are becoming more and more autonomous.

II. SCOPE OF PROJECT

Nowadays in the current railway systems, it is becoming necessary to have safetyelements in order to avoid accidents. the causes that can provoke seriousaccidents is the existence of obstacles on the tracks, either fixed or mobile.

This project deals about one of the efficient methods to avoid train collision andobstacle detection. So, this issue becomes our priority to solve it. The system which we are proposing helps to overcome this social problem faced in almost every city of India. A key aspect of our project is to identify a crack in a track, and to alert the office at the very same movement. The system sets an example on how to use

sensors and GPS efficiently for railway track crack detection and the technology can be used at domestic and at commercial places with future vision.

Instead of using manual method of crack detection, the use of this method helps inefficient and fast management of crack detection in track. Also the respective monitoring office will gets instant information about crack detection which will also reduce unwanted workload on them. And then key aspect to keep our city secured from the accidents caused by improper and unmaintained track.

III.ADOPTED METHODOLOGY

- Analysis of the exiting situation and the exact nature of problem faced through of different technologies used the system.
- discussions with the project guide Study of process With the help of the guide the specifications of the program were decided and then implementing the project.
- Use of ultrasonic sensor to interface with microcontroller for railway track system
- Testing, development and troubleshooting still underway to enhance user interface.

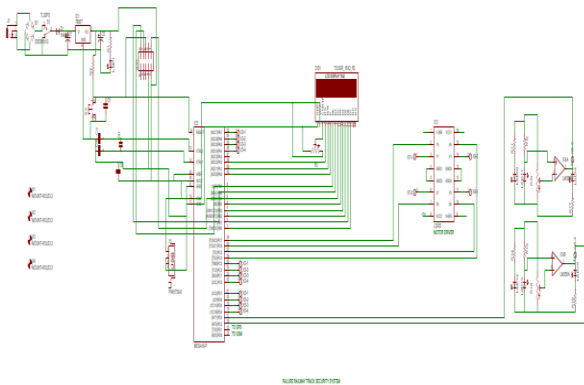

Fig: Circuit Diagram

IV. CIRCUIT DIAGRAM DISCRPTION

- Fig. shows the circuit diagram of automatic railway track crack detection system. In our project LPC2148 controller is used
- Circuit diagram consisting of following section
 - Power supply unit
 - Display unit
 - Crack sensing circuit
 - Max 232 serial communication interface
- Crack sensing circuit-
Crack sensing circuit is used for sensing the crack present on the railway track. Here ultrasonic sensor and MEMS sensor are used for detecting obstacle present on the railway track .
- Display unit-
Display unit is used for displaying the longitude and latitude position of that area. 16X2 display is used.
- Max 232 serial communication interface-

For the purpose of sending message to the authority person GSM (Global system for mobile communication) modem is used. The GSM modem is operated on the serial communication mode. But microcontroller uses TTL logic. So we need to convert TTL logic into RS232 serial communication interface . MAX 232 is used. MAX 232 is TTL to RS 232 voltage level converter.

DB9 connector is used for connecting the RS232 communication interface.

V. WORKING

In this project circuits, sensors & motor are used which require +12V & +5V (DC) supply, to fulfill this requirement we have used following circuit of power supply which provides regulated +12V & +5V(DC).As shown above Transformer (15V/1A) is used to down convert the AC up to 15V . 4 diodes (IN4007) are connected to secondary of transformer in bridge for rectifying AC into DC. Capacitor 1000 μ f & 1 μ f are used as a filter red led shows that rectification and filtering is ok.7812 IC is used as a 12V regulator it converts 15V into regulated +12V DC, yellow led shows that output of 7812 is ok.7805 IC is used as a 5V regulator it converts 12V into regulated+5V DC, green led shows that output of 7805 is ok.

Thus the microcontroller works on the voltage of 5V DC which is provided by the power supply from 230 AC mains to 5V regulated DC voltage. Hence, our project works starting from this conversion of 230v AC to 5V DC voltage for the running of our railway track crack detector machine.

VI.DISADVATAGES OF EXISTING SYSTEM AND ADVANTAGES OF PROPOSED SYSTEM

Disadvantages of Existing System:

- Existing systems are not able to predict the cracks properly on the railway track.
- Existing systems are not able to manage when the cracks are small or the speed at which the train can pass safely on the crack.

Advantages of Proposed System:

- Establish management structure based on performance evaluation and monitoring process.
- Enhance the percentage of efficiency.
- Facility to send alerts/warnings to particular train drivers on possible collisions, derailment through the system.

FUTURE SCOPE:

- 1.The system sets an example on how to use wireless network efficiently for Railway Track Crack detection and the technology can be used at domestic and at commercial places with future vision.
- 2.Instead of manual method of crack detection a more advanced accelerometer sensor are compatible technology can be used.
- 3.In this project, we are using MEMS and Ultrasonic sensors for detecting the breakage and obstacles in track.
- 4.In future, we will also using the cctv systems with IP based camera for monitoring the visual videos captured from the track.
- 5.It will also increase the security for the both rails and passengers from terrorism, crime

VII. CONCLUSION

This project discusses the critical safety techniques for high-speed train operation environment based on the train control system. In order to ensure safe operation of trains, we propose a wireless network access framework

according to the monitoring network of surrounding environment and the deployment of transition network to avoid collision of trains and obstacle detection.

System has ability to pin point the location and other attributes of an operational

train in an economical accurate manner. The goal of this work is to design and

implement a cost effective and intelligent and wireless based railway track Anti Collision and breakage detection System to avoid accident.

VIII. REFERENCE

1. M.Pradeep & K. Naganarasaiah Goud(2013)[1] This paper represents "Damage Detection of Railway Track by Sensor International Journal of Engineering Trends and Technology (IJETT) – Volume 6 Number 1- Dec 2013
2. S. Ramesh -"Detection of Cracks and Railway Collision Avoidance System", International Journal of Electronic and Electrical Engineering ISSN 0974 -2174 Volume 4, Number 3 (2011), pp. 321-327
3. Kalpana Sharma¹, Jagdish Kumawat- International Journal of Computer Applications (0975 – 8887) Volume 96– No.25, June 2014 Railway Security System based on Wireless Sensor Networks: State of the Art
4. K.Bhargavi , M.Janardhana Raju-International Journal of Advanced Research in Electronics and Communication Engineering (IJARECE) Volume 3, Issue 9, September 2014 1230 ISSN: 2278 – 909X All Rights Reserved © 2014 IJARECE
Railway Track Crack Detection Using LED-LDR Assembly
5. Saravana moorthy.,N.Muruganathan International Journal of Advanced Research in Electronics and Communication Engineering (IJARECE) Volume 4, Issue 1, January 2015 64 ISSN: 2278 – 909X All Rights Reserved © 2015 IJARECE
automatic identification of obstacles and crack sensing scheme in rail tracking system
- 6 .Dr.Sri Rajitha & L.Chandra Shekar(2015)International Journal & Magazine of Engineering, Technology, Management and Research A Peer Reviewed Open Access International Journal An Embedded Based Railway Track fault Detection
 - a. Using ARM7LPC2148.
7. J. Banuchandar, V. Kaliraj,P. Balasubramanian, S. Deepa, N.Thamilarasi "automated unmanned railway level crossing system" International Journal of Modern Engineering Research (IJMER) Vol.2, Issue.1, Jan-Feb 2012 pp-458-463 ISSN: 2249-6645
8. GuoXie, XinhongHei, Hiroshi Mochizuki, Sei Takahashi and Hideo Nakamura.
Line Using VDM++" IJR International Journal of Railway Vol. 5, No. 2 / June
9. S. Ramesh "Detection of Cracks and Railway Collision Avoidance System", International Journal of Electronic and Electrical Engineering ISSN 0974 -2174 Volume 4, Number 3 (2011), pp. 321-327
10. Wojnarowski, Robert John Welles, II, Kenneth , William Paul, "Electromagnetic system for railroad track crack detection and traction enhancement", Patent US6262573, July 2010
11. Yu, L., N. Wang, et al. (2007). Real-time forest fire detection with wireless sensor networks. Wireless Communications, Networking and Mobile Computing
12. "Cost effective system for railway level crossing protection" Konkani Railway Corporation limited. Special Issue on NDT of Rails 47(6) 346-353 (2005)
13. [BHS] Babenko, P., Harper, D., Shah, M.: Towards the unsupervised real-time rail gauge measurement. In preparation for SPIE Machine Vision and Applications.
14. [BS08] Babenko, P., Shah, M.: MinGPU: a minimum GPU library for computer vision. IEEE Journal of Real-Time Image Processing, Vol. 3, pp. 255-268, 2008.
15. [FRA] Federal Railroad Administration. Office of Safety Analysis: Online database of track accidents.
16. Risk Analysis of Derailment Induced by Rail Breaks – a Probabilistic approach, Jianmin Zhao, University of Birmingham, Andrew H. C. Chan, Professor, University of Birmingham, Alan B.
17. Journal IJAICT Volume -1, Issue-1, May 2014,ISSN 2348 – 9928, CRACK detection system for railway track by using ultrasonic
18. AND PIR SENSOR, Prof. P.Navaraja Assistant Professor, Electronic and Communication Engineering,Mahendra Institute of Technology, Namakkal, Tamilnadu, India.
19. Journal Richard J. Greene, John R. Yates and Eanna Patterson, "Crack detection in rail using infrared methods", Opt. Eng. 46, 051013, May2007.
20. Paper IJREAT International Journal of Research inEngineering & Advanced Technology, Volume 2, Issue2, Apr-May, 2014, ISSN: 2320 – 8791, Innovative Railway Track Surveying With Sensors and Controlled By Wireless Communication by Athira Ajith¹, AswathyK S², Binoy Kumar H³, Dantis Davis⁴,Lakshmi S Pai⁵,
21. Janahanlal P Stephen.
22. Paper I. Milev and L. Gruendig, _Rail track data base of German rail The future automated maintenance,_ in Proc. INGE0 FIG Regional Central Eastern Eur. Conf. Eng.Surv., Bratislava, Slovakia,Nov. 11-13, 2004,pp. 1-8.
23. Paper J. Trehag, P. Handel, and M. Ogren,Onboard estimation and classification of a railroad curvature,IEEE Trans. Instrum. Meas., vol. 59, no.3,pp. 653-660, Mar.2010.
Paper L. Beales, Track system requirements,Railway Group Standards, GC/RT5021, Railway Safety,London, Oct.2003
- Journal B. Akpınar, A new measurement systemdesign for determining the
Technical Univ.,Istanbul,Turkey,2009
24. An article on LED-LDR Based Railway Crack Detection Scheme on internet open access articles

25. C. Saravanan, Dr. M. A. Panneerselvam, and I. William Christopher, "A Novel Low Cost Automatic Solar Tracking System," International Journal of Computer Applications, 31(9), pp.62-67, October 2011.